

Service installation of hardtop

Work to be completed

Special tools and workshop equipment required

- Special tool T40003
- Protective sheeting AKL 448 300 04
- Lubricating paste G 000 150

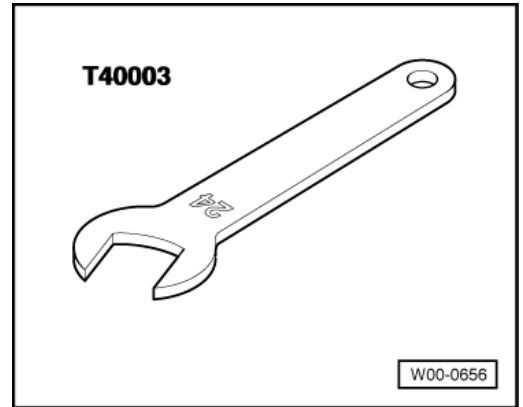

Assembly tool

Tool kit with assembly tool is part of service installation kit => Page 61-144.

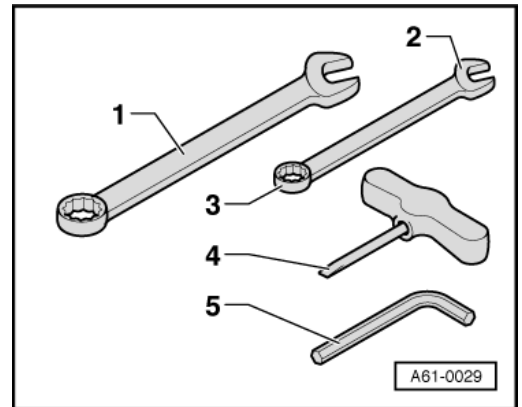

- 1 - 17 mm ring/open-ended spanner
- 2 - 11 mm open-ended spanner
- 3 - 10 mm ring spanner
- 4 - T-handle key
- 5 - Allen key

Table of operations involved

Notes:

- Before starting hardtop service installation, determine work involved and kit required by way of vehicle identification number/production date.
- Attention must be paid to whether convertible top is actuated manually or electrohydraulically.

Vehicle identification no. 1)			8G_NA 010 800	8G_TN 011 300 8G_VN 001 050	8G_VN 006 400	8G_WN 002 530 2) 8G_WN 003 500 3)	Hardtop series launch
Production date			04.92	07.96	04.97	08.97	08.97
Item	Work to be completed	Part no.					
1	- Replace hexagon bolt at mounting bracket on left and right with studs (LU buffer for lid)	8G0 860 593	X				
2	- Fit summer/winter wiring harness	8G0 971 211	X	X			

- 1) Vehicle identification number may differ slightly on account of series launch
- 2) Vehicles with electrohydraulic convertible top actuator mechanism
- 3) Vehicles with manual convertible top actuator mechanism

	8G_TN 011	8G_WN 002

Vehicle identification no. 1)			8G_NA 010 800	011 300 8G_VN 001 050	8G_VN 006 400	002 530 2) 8G_WN 003 500 3)	Hardtop series launch
Production date			04.92	07.96	04.97	08.97	08.97
Item	Work to be completed	Part no.					
3	- Route connector at micro-switch cable from left luggage compartment side panel into left of convertible top compartment using adapter lead (Work does not apply to vehicles with electrohydraulic convertible top actuator mechanism)	8G0 971 157	X 3)	X 3)	X 3)		
4	- Fit reinforcement for left and right mounting bracket	8G0 817 227 8G0 817 228	X	X	X	X	
5	- Fit lower part of left and right mounting bracket	8G0 817 175A 8G0 817 176A	X	X	X	X	

1) Vehicle identification number may differ slightly on account of series launch

2) Vehicles with electrohydraulic convertible top actuator mechanism

3) Vehicles with manual convertible top actuator mechanism

Vehicle identification no. 1)			8G_NA 010 800	8G_TN 011 300 8G_VN 001 050	8G_VN 006 400	8G_WN 002 530 2) 8G_WN 003 500 3)	Hardtop series launch
Production date			04.92	07.96	04.97	08.97	08.97
Item	Work to be completed	Part no.					
6	- Replace actuator switch for heated rear window by actuator switch with time function	4A0 941 503F	X	X	X	X	X
	- Bond protective sheeting onto scuttle in area of convertible						

7	top locking mechanism (under chrome trim) and onto resting surfaces of convertible top hold-downs on left and right	AKL 448 300 04	X	X	X	X	X
8	- Grease front and rear locking mechanism at hardtop	G 000 150	X	X	X	X	X

1) Vehicle identification number may differ slightly on account of series launch

2) Vehicles with electrohydraulic convertible top actuator mechanism

3) Vehicles with manual convertible top actuator mechanism